

JOURNAL OF THE AMERICAN CHEMICAL SOCIETY

Registered in U.S. Patent Office. © Copyright, 1975, by the American Chemical Society

VOLUME 97, NUMBER 21

OCTOBER 15, 1975

The Importance of Nonbonded Attraction in 2-Butene

Nicolaos D. Epiotis,^{*1a} Ronald L. Yates,^{1a} and Fernando Bernardi^{1b}

Contribution from the Department of Chemistry, University of Washington, Seattle, Washington 98195, and the Istituto di Chimica Organica, Università di Bologna, 40136 Bologna, Italy. Received January 25, 1975

Abstract: The preferred geometry of any molecule can be viewed as arising from a balance of one-electron factors and "steric" effects. An orbital symmetry analysis is used to evaluate these one-electron factors in 2-butene and it is shown that the concepts of nonbonded attraction and aromaticity are important in understanding torsional isomerism in this molecule. The results of *ab initio* calculations are presented to support the conclusions reached by one-electron molecular orbital theory.

The molecule 2-butene is one of the key molecules often used in an introductory organic chemistry course in order to illustrate an important concept. In particular, the geometric isomerism of 2-butene is the topic which is routinely utilized to illustrate how "steric effects" can determine structural preferences. The usual rationalization of the greater stability of *trans*- relative to *cis*-2-butene is that the two "bulky" methyl groups repel each other in the *cis* geometry. Hence, the *trans* isomer, where this repulsion, often implied to be a van der Waals repulsion, is minimized by virtue of having the two methyl groups far apart, is the more stable of the two geometric isomers.^{2a}

It can be said that both the pioneer as well as the more recent studies of the relative stability of the geometric isomers of 2-butene^{2b} and 1,2 dialkylethylenes³ had served as the basis for a model according to which "steric effects" were the key factor which determines geometric preference and special effects like *d* orbital conjugation and van der Waals attraction were invoked in order to account for the occasional unexpected observation of a molecule which exists in a preferred *cis* form.⁴ In short, we can say that in this "older" model "steric effects" were regarded as the important effects and "attractive effects" were simply postulated whenever an interpretation of experimental data seemed untenable otherwise. However, as time went on, a curious situation arose: the number of cases where a molecule was found to be more stable in a "crowded" rather than an "uncrowded" geometry progressively increased to an extent that may even have exceeded the number of cases where the reverse situation held true. Thus, it became apparent to us that an important common denominator in structural problems is not only "steric effects" but also "nonbonded attraction". In recent publications,⁵⁻⁸ we have argued that orbital symmetry dictates that there will be an attractive nonbonded interaction between any two vicinal groups in 1,2-disubstituted ethylenes or ethanes provided that these two groups carry a total of $4N \pi$ or $4N \sigma$ type electrons, respectively. Accordingly, it has been predicted that all 1,2-disubstituted ethylenes and ethanes will *tend* to exist in their most

"crowded" form, i.e., the former in a *cis* geometry and the latter in a *syn* conformation, unless interelectronic and internuclear repulsive effects make such stereochemical arrangements energetically unfavorable. This latter possibility is reflected by the greater stability of *trans*-1,2-dialkylethylenes or the preferred anti conformation of 1,2-dialkylethanes,⁹ which can be viewed as the result of dominance of repulsive interactions, and the "gauche effect" in 1,2-disubstituted ethanes, which can be viewed as the result of a compromise between repulsive and attractive interactions. In a formal quantum mechanical sense we distinguish three important factors which control stereochemical preferences in molecules: (a) a one-electron, orbital symmetry based factor which can be responsible for nonbonded attractive or repulsive interactions and which can be revealed by a MO treatment which utilizes an effective one-electron hamiltonian operator; (b) a two-electron coulombic repulsive factor which is reproduced by the two-electron part of a complete hamiltonian operator; (c) a coulombic internuclear repulsive factor.

Factors (b) and (c) can be grouped under the heading "steric effects" and they always tend to favor the less "crowded" structure. On the other hand, factor (a) cannot be intuitively predicted. Indeed, the triumphs of modern theoretical organic chemistry amount to the elucidation of such one-electron factors.¹⁰ In this work, we wish to show that the preferred geometry and conformations of 2-butene, although they are dominated by "steric effects", depend crucially upon one-electron nonbonded attractive effects of the type we have suggested in our previous work. In other words, 2-butene is the model system which, unexpectedly, illustrates in a most convincing way the power of orbital symmetry arguments and the importance of nonbonded attraction in determining the shape of molecules.

2-Butene and the Concept of Nonbonded Attraction

The six conformations of 2-butene are shown below along with definitions to be used throughout the rest of the present work, e.g., the label C_{ss} corresponds to the *cis* iso-

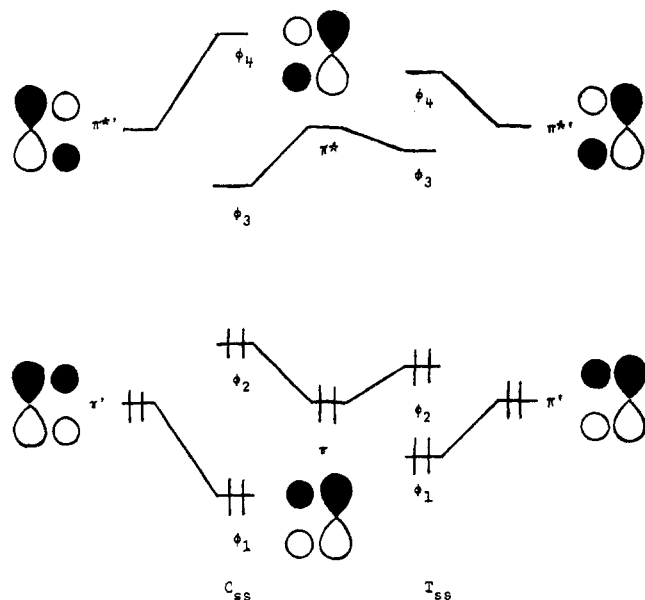
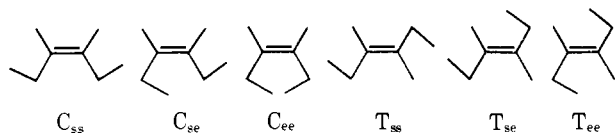

Figure 1. Interaction diagram for the Ba + Bb union in the C_{ss} and T_{ss} conformations of 2-butene.



mer where the in plane hydrogens of the methyl groups are staggered relative to the double bond. Our qualitative MO approach can best be illustrated by consideration of the relative stabilities of the C_{ss} and T_{ss} .

In the course of our analysis, we shall make use of the following general results of one-electron MO theory.

(a) The interaction of a doubly occupied MO, ϕ_i , with a vacant MO, ϕ_j , leads to two-electron stabilization which is inversely proportional to the energy separation of the two MO's, $\epsilon_i - \epsilon_j$, and directly proportional to the square of their overlap integral, S_{ij} . This is a well-known result of perturbation theory and the assumptions involved in its derivation are valid for the systems studied in this work. The algebraic expression for the two-electron stabilization is given below:

$$\Delta E^{(2)} = \frac{S_{ij}^2(k - \epsilon_i)^2}{(\epsilon_i - \epsilon_j)} \quad (1)$$

Equation 1 is derived from the standard perturbation expression with the assumption that the interaction matrix element, H_{ij} , is proportional to the overlap S_{ij} , i.e., $H_{ij} = kS_{ij}$.¹¹

(b) The interaction of two doubly occupied MO's, ϕ_i and ϕ_j , leading to net four-electron destabilization which increases as the overlap integral of the two MO's, S_{ij} , and the mean of their energies, $(\epsilon_i + \epsilon_j)/2$, increases.¹² This result is obtained by application of the variational method to the case of a two-orbital four-electron interaction and involves no special assumptions other than the usual approximation of the interaction matrix element as a linear function of the overlap integral. The four-electron destabilization energy is given by the equation

$$\Delta E^{(4)} = \frac{4S_{ij}^2}{1 - S_{ij}^2} (\epsilon_0 - k) \quad (2)$$

where ϵ_0 is the mean of the energies of the unperturbed MO's, ϕ_i and ϕ_j .

In general, 2-butene can be viewed, theoretically, as the result of the union of a central ethylenic bond (fragment A) with a fragment (B) composed of the two vicinal methyl groups. Fragment B, in turn, can be further dissected into the elementary fragments Ba and Bb, the wave functions of which are known. These "dissections" are illustrated for the case of the C_{ss} conformation below:

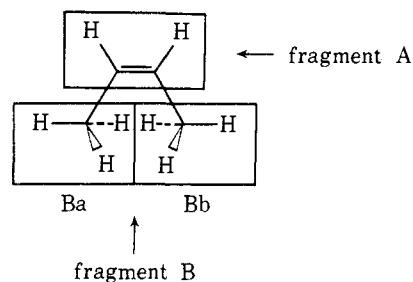

We first proceed to construct the π MO's of fragment B from the π MO's of the methyl groups (fragments Ba and Bb). Figure 1 depicts the interactions between the π MO's of the two methyl groups. The key difference between the two conformations C_{ss} and T_{ss} is that in the former case the

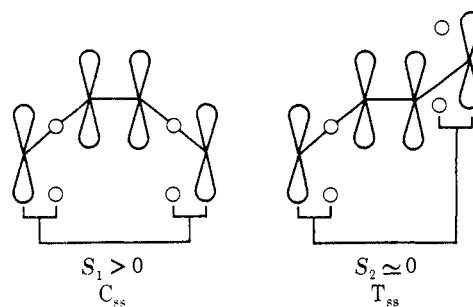

two 1s AO's of the out of plane methyl hydrogens of fragment Ba can overlap with those of fragment Bb, while in the latter case this overlap is substantially reduced. Since the interaction matrix element can be assumed to be proportional to the corresponding overlap integral, i.e., $H_{ij} = kS_{ij}$, it is predicted that the absolute magnitude of the interaction matrix elements between the π type MO's of the methyl groups will vary in the way shown below. The quantitative results are shown in Table I.

$\pi' - \pi$	$C_{ss} > T_{ss}$
$\pi' - \pi^*$	$C_{ss} > T_{ss}$
$\pi^* - \pi$	$C_{ss} > T_{ss}$
$\pi^* - \pi^*$	$C_{ss} > T_{ss}$

On the basis of these results, and eq 1 and 2, we predict that the two-electron stabilization resulting from $\pi' - \pi^*$ and $\pi - \pi^*$ will favor the C_{ss} conformation. However, the four-electron destabilization arising from the $\pi - \pi'$ interaction will favor the T_{ss} conformation. We expect, therefore, that the four-electron destabilization which favors the T_{ss} conformation will dominate the two-electron stabilization which favors the C_{ss} conformation because $S_{\pi - \pi'}$ and $S_{\pi' - \pi^*}$ will be much smaller than $S_{\pi \pi'}$.

Once we have examined the energetics of the MO interactions which obtain in the course of the union of the π systems of the methyl groups, we return to the interaction diagram of Figure 1 in order to make certain observations about the π MO's of fragment B. Specifically, it can be seen that, as a result of the orbital interaction pattern discussed before, the energies of the various π MO's of fragment B vary as follows, depending upon the geometry of union:¹³

Table I. Absolute Values (au) of the Interaction Matrix Elements in Ba + Bb Union for the C_{SS} and T_{SS} Conformations

Matrix element ^a	C _{SS}	T _{SS}
$H_{\pi'\pi}$	0.0795	0.0032
$H_{\pi'\pi^*}$	0.0109	0.0009
$H_{\pi^*\pi}$	0.0109	0.0009
$H_{\pi^*\pi^*}$	0.0683	0.0001

^a The matrix element was approximated by a linear function of the overlap, $H_{ij} = kS_{ij}$. The energy constant k was set equal to -1.459 au (see ref 12). The MO overlap integrals were calculated using eigenvectors and AO overlap integrals computed by the SCF-MO-INDO method.²³

$$\epsilon_1(C_{SS}) < \epsilon_1(T_{SS})$$

$$\epsilon_2(C_{SS}) > \epsilon_2(T_{SS})$$

$$\epsilon_3(C_{SS}) < \epsilon_3(T_{SS})$$

$$\epsilon_4(C_{SS}) > \epsilon_4(T_{SS})$$

We are now prepared to consider the construction of the composite system of 2-butene from the π system of fragment B and the ethylenic π MO's. The orbital interactions which obtain in this union are depicted in Figure 2. On the basis of the principles outlined before, we can determine that the π - ϕ_3 and ϕ_2 - π^* interactions are more stabilizing in the C_{SS} conformation and, also, that the π - ϕ_1 interaction is more destabilizing in the T_{SS} conformation. This interesting result and its general implications have been discussed recently elsewhere.¹⁴ Now, we expect that since the MO overlap integral $S_{\pi\phi_1}$ will be larger than the corresponding overlap integral $S_{\pi\pi'}$ in the Ba + Bb union, the four-electron destabilization which favors the T_{SS} conformation in the Ba + Bb union will tend to be dominated by the four-electron destabilization term which favors the C_{SS} conformation in the A + B union. Furthermore, the two-electron stabilization term which favors the C_{SS} conformation in the Ba + Bb union is augmented by the two-electron stabilizing term which favors the C_{SS} conformation in the A + B union. In general, the four-electron destabilization of the first union favoring the least-crowded structure will tend to be counteracted by the four-electron destabilization of the second union which favors the more crowded structure. As a result, the relative two-electron stabilization which is greater in the second union than in the first union will favor a greater overall stabilization of the more crowded structure.

The previous analysis focused upon the energetics of changes which accompany the union of two fragments in a specified geometry; i.e., it was an "energy approach". Further insights are gained by adopting a "charge transfer approach". In this case, conceptual simplicity can be achieved by using perturbation theory with neglect of overlap since we have already attested to the fact that overlap repulsion in a nonaromatic and aromatic conformation differs only by a small amount which may, in certain instances, favor the more "crowded" conformation. Hence, one does not lose essential information by neglecting overlap in the "charge transfer approach". This approach and the principles involved have been discussed in our previous work.⁵

In the "charge transfer" approach, we are concerned with the bonding changes which occur in the two conformations, C_{SS} and T_{SS}, as a result of the ϕ_2 - π^* and π - ϕ_3 stabilizing interactions which give rise to charge transfer from ϕ_2 to π^* and π to ϕ_3 . Examination of Figure 2 leads to clear cut predictions about the relative magnitude of π bonding between any pair of atoms in the C_{SS} and T_{SS} conformations. Recalling that the ϕ_2 - π^* and π - ϕ_3 interactions are stronger and lead to greater charge transfer in the C_{SS} conformation,

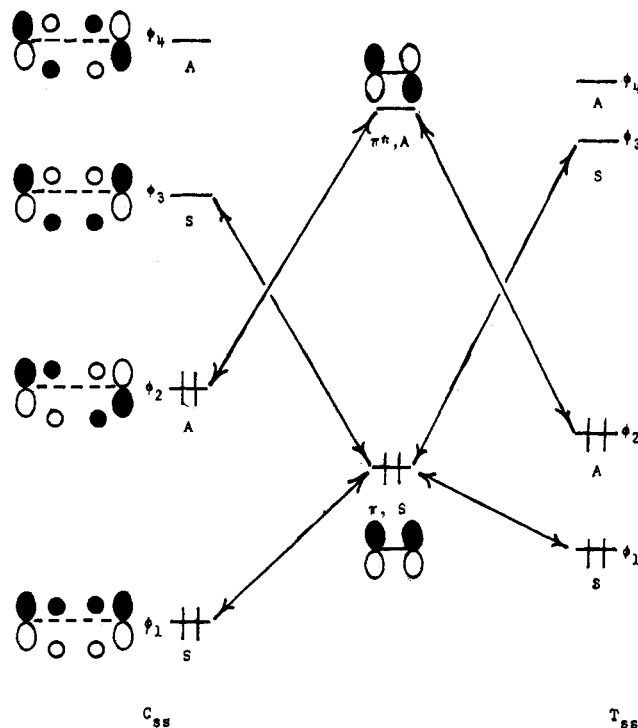

Figure 2. Interaction diagram for the A + B union in the C_{SS} and T_{SS} conformations of 2-butene. Dominant orbital interactions are designated by arrows.

Table II. π Overlap Populations of the C_{SS} and T_{SS} Conformation of 2-Butene

Atom pair	Predicted π bonding in C _{SS} relative to T _{SS}	π overlap populations			
		STO-4G		4-31G	
		C _{SS}	T _{SS}	C _{SS}	T _{SS}
H ₁ -C ₂	-	0.3686	0.3694	0.3883	0.3904
H ₁ -C ₃	+	-0.0060	-0.0061	-0.0094	-0.0168
H ₁ -C ₄	-	-0.0032	-0.0031	-0.0036	-0.0063
H ₁ -C ₅	+	0.0000	0.0001	0.0003	0.0000
H ₁ -H ₆	+	0.0004	0.0000	0.0003	0.0000
C ₂ -C ₃	+	0.0049	0.0033	-0.0164	-0.0228
C ₂ -C ₄	-	-0.0015	-0.0015	-0.0069	-0.0078
C ₂ -C ₅	+	-0.0001	0.0000	-0.0005	0.0000
C ₂ -H ₆	+	0.0000	0.0001	0.0003	0.0000
C ₃ -C ₄	-	0.1996	0.1985	0.2764	0.2731
C ₃ -C ₅	-	-0.0015	-0.0015	-0.0069	-0.0078
C ₃ -H ₆	-	-0.0032	-0.0031	-0.0036	-0.0063
C ₄ -C ₅	+	0.0049	0.0033	-0.0164	-0.0228
C ₄ -H ₆	+	-0.0060	-0.0061	-0.0094	-0.0168
C ₅ -H ₆	-	0.3686	0.3694	0.3883	0.3904

one can predict whether a certain π interaction between any pair of atoms will be more bonding or antibonding in the C_{SS} conformation relative to the T_{SS} conformation. These predictions are given in Table II.

In summary, a MO analysis of the relative π energies of the C_{SS} and T_{SS} conformations leads to the prediction that the former will be more stable, a preference which can be attributed to a nonbonded attractive interaction between the two methyl groups. Once more, we emphasize that the term nonbonded attraction denotes a stabilizing effect brought about by virtue of having two atoms or groups in proximity to each other. A similar approach can be used for comparing the stabilization of the C_{se}, C_{ee}, T_{se}, and T_{ee} conformations relative to that of the C_{SS} conformation. Since appreciable H₁-H₆ π bonding overlap obtains only in the C_{SS} conformation, we would expect this conformation to

have lower energy than the C_{se} , C_{ee} , T_{se} , and T_{ee} conformations, provided that "steric effects" are nearly the same in all cases. However, since steric effects are expected to be important, the relative energies of the six structures of 2-butene will be the result of a compromise between nonbonded attraction and steric repulsion. However, the important conclusion is that no matter how this balance is achieved, π nonbonded attraction is at a maximum in the C_{ss} conformation and will tend to influence conformational preferences in a predictable manner. A related problem, where the MO analysis given above can be effectively utilized, concerns the rotational barrier of the methyl group in the *cis* and *trans* geometries. In general, rotation of the methyl group in either geometric isomer of 2-butene will be accompanied by a decrease or increase of nonbonded attraction. Hence, the relative magnitude of the rotational barriers in *cis*- and *trans*-2-butenes could be predicted on the basis of the concept of nonbonded attraction. We shall consider this point in greater detail in a subsequent section.

A simplifying reduction of the above detailed analysis of the conformational properties of 2-butene can be accomplished by recourse to the concept of aromaticity shown to be directly applicable to problems of geometrical and conformational isomerisms. Specifically, we see that the C_{ss} conformation resembles a 6π -electron Hückel aromatic system while the C_{ee} conformation resembles a 6σ -electron Hückel system:

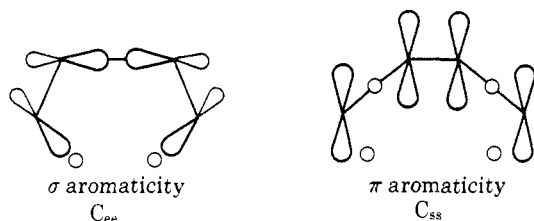

In short, our analysis indicates that one-electron factors will favor the C_{ee} and C_{ss} conformations over the T_{ee} and T_{ss} conformations, respectively. However, *ab initio* calculations are required in order to determine the balance of the one-electron effects and the coulombic (nuclear and electronic) repulsive effects.

Ab Initio Computations

Radom and Pople¹⁵ have investigated theoretically the six conformations of 2-butene using an *ab initio* SCF-MO treatment at the minimal basis (STO-3G) level¹⁶ but the calculations were not performed upon geometries which were fully optimized. In order to evaluate fully the orbital symmetry considerations presented earlier in this paper, we have carried out a more extensive *ab initio* geometry optimization of the six conformations of 2-butene. The optimum geometry of each conformation has been determined by *ab initio* SCF-MO calculations using an STO-4G basis set since it is known that geometries of molecules containing first row elements are accurately reproduced at this computational level. All computations have been carried out using the Gaussian 70 series of programs.¹⁸ In these computations we have kept fixed, for all the conformations, the following geometrical parameters: (i) the C-H bond lengths and angles of the methyl groups at 1.09 Å and 109.5°, respectively, and (ii) the C-H bond lengths and the angle HCC of the ethylene fragment at 1.07 Å and 120°, respectively. For the C_{ss} and T_{ss} conformations, the following parameters have been optimized: (a) the angle $\beta(C_2C_3C_4)$, (b) $r(C_2-C_3)$, (c) $r(C_3-C_4)$, and (d) the angle $\alpha(H_1C_2C_3)$. For the remaining conformations (b) and (c) were kept constant and the angles α and β were reoptimized. The computed optimum geo-

metrical parameters are listed in Table III while the corresponding total energies, together with the nuclear and electronic components, are given in Table IV. It is interesting to notice that the CCC angle remains quite large (126.4°) in the C_{ee} conformation and that the methyl group symmetry axis does not coincide in this case with the C-C bond; the tilt angle of the threefold axis to the C-C bond is 1.7°. Both the CCC angle and the tilt angle assume values which tend to reduce the steric repulsion between the methyl groups. The tilt angle decreases in the C_{se} conformation and is practically zero in C_{ss} and all the *trans* conformations. These results are in good agreement with those obtained by electron diffraction in which the CCC angle is 125.4° in *cis*-2-butene and 123.8° in *trans*-2-butene.^{19a} Also it is found, by electron diffraction and microwave spectroscopy, that the symmetry axis of the methyl group in *cis*-2-butene does not coincide with the C-C bond.^{19a,b}

Since energy differences at the STO-4G level may not be accurate, we have carried out computations at the 4-31G level²⁰ with the geometries optimized at the STO-4G level. The resulting total energies together with the nuclear and electronic components are listed in Table IV. As can be seen, the relative stabilities of the six conformations of 2-butene going from the minimal to the extended level remain unchanged. Furthermore, while the 4-31G energy values are, as expected, all significantly lower than those at the STO-4G level, the energy differences at the two levels are almost exactly the same. In addition to the relative stabilities of the six conformations of 2-butene, the methyl rotational barriers can also be obtained from the *ab initio* computations. These are listed in Table V. Finally, the overlap populations which have been obtained from the *ab initio* computations are of crucial significance in testing the validity of the theoretical MO analysis presented in the previous section.

Discussion

Ab initio calculations provide various quantities of interest which can be used in testing a general theoretical model. We shall focus our attention on the following.

- Total energy of a conformer, E_T .
- Nuclear repulsion energy of a conformer, E_N . This quantity provides an index of the steric repulsion present in a molecule.
- Total π overlap populations, N_T^π . This quantity provides an index of the degree of π bonding which obtains in a molecule; if π interactions are of key importance, the relative N_T^π 's will parallel the relative E_T 's.
- Nonbonded π overlap population, $N^\pi(X-Y)$. This quantity provides an index of the sign and magnitude of a π nonbonded interaction between two groups X and Y. *This quantity is a reliable index of nonbonded interaction only when its relative magnitude parallels the relative magnitude of N_T^π .* This is true because the interconversions of two torsional isomers result in multiple overlap population changes, the sum of which is expected to have the same sign as the change of the nonbonded π overlap population. For example, the interconversion of T_{ss} and C_{ss} is expected to be followed by an increase in N_T^π as well as $N^\pi(CH_3-CH_3)$.

- Nonbonded σ overlap populations, $N^\sigma(X-Y)$. This quantity provides an approximate index of the sign and magnitude of a σ nonbonded interaction.

The first important result of the calculations is the prediction of the relative stabilities of the various conformations of 2-butene. The results obtained with the 4-31G and STO-4G basis sets are summarized in Table VI.

We first examine the relative stabilities of the three *trans* conformations. From Table IV we see that the relative

Table III. Optimum Geometrical Parameters of the Various Conformations of 2-Butene Computed at the STO-4G Level

	C_{ss}	C_{se}	C_{ee}	T_{ss}	T_{se}	T_{ee}
Angle β , deg	124.1	125.79	126.9	124.0	124.3	124.58
$r(C_2-C_3)$, Å	1.5261	1.5261	1.5261	1.5313	1.5313	1.5313
$r(C_3-C_4)$, Å	1.3105	1.3105	1.3105	1.3164	1.3164	1.3164
Angle α_1 , deg	109.3	110.4	111.2	109.9	109.6	109.7
Angle α_2 , deg	109.3	108.8	111.2	109.9	109.2	109.7

Table IV. Nuclear (E_N), Electronic (E_{E1}), and Total (E_{Tot}) Energies (au) of the Various Conformations of 2-Butene Compared at the STO-4G and 4-31G Levels

	C_{ss}	C_{se}	C_{ee}	T_{ss}	T_{se}	T_{ee}
STO-4G						
E_N	118.57290	118.13342	117.86824	115.63221	155.59300	115.56831
E_{E1}	-273.92021	-273.48149	-273.21682	-270.97890	-270.94214	-270.91984
E_{Tot}	-155.34731	-155.34807	-155.34858	-155.34669	-155.34914	-155.35153
4-31G						
E_N	118.57287	118.13406	117.86837	115.63225	115.59300	115.56831
E_{E1}	-274.45356	-274.01562	-273.75065	-271.51156	-271.47534	-271.45356
E_{Tot}	-155.88069	-155.88155	-155.88227	-155.87931	-155.88234	-155.88524

Table V. Methyl Rotational Barriers in *cis*- and *trans*-2-Butene

Transformation	Exptl, kcal/mol	4-31G, kcal/mol	STO-4G, kcal/mol
$C_{ee} \rightarrow T_{se}^a$	0.45-0.73 ^c	0.450	0.319
$T_{ee} \rightarrow T_{se}^b$	1.95 ^d	1.814	1.495

^a Threefold rotational barrier in the *cis* isomer. ^b Threefold rotational barrier in the *trans* isomer. ^c T. N. Sarachman, *J. Chem. Phys.*, 49, 3146 (1963); J. E. Kilpatrick and K. S. Pitzer, *J. Res. Natl. Bur. Stand.*, 37, 163 (1946). ^d J. E. Kilpatrick and K. S. Pitzer, *ibid.*, 37, 163 (1946).

order of stability is found to be $T_{ee} > T_{se} > T_{ss}$ with both the STO-4G and 4-31G basis sets. This order can be explained by invoking the same factors which favor eclipsed over staggered propene and already have been discussed in the literature.²¹ Furthermore, it is interesting to note that this order is also paralleled by the relative order of total π overlap populations, an observation which suggests that the relative stability of the various conformers of *trans*-2-butene is the result of π interactions. The relative stabilities of the cisoid conformers, on the other hand, vary, with both basis sets, in the order $C_{ee} > C_{se} > C_{ss}$ (Table IV). This result can be partially understood on the basis of π vs. σ aromaticity as discussed previously and as illustrated by the key overlap populations tabulated below. As expected, π aromaticity, as demonstrated by the (CH_3-CH_3) π overlap

population, is at a maximum in the C_{ss} and small in the C_{ee} and C_{se} conformations. A slight disagreement between the

	C_{ss}	C_{se}	C_{ee}	
$N^\pi(CH_3-CH_3)$	0.0013	0.0006	0.0005	4-31G
$N^\sigma(H_C-H_{C'})$	0.0000	0.00010	0.00093	4-31G

two basis sets, which does not affect any conclusions, is to be noted here. Specifically, the $N^\pi(CH_3-CH_3)$ indices are paralleled by the N_T^π indices in the case of the STO-4G basis set, but not in the case of the 4-31G basis set. In this latter case, C_{ee} is predicted to enjoy greater π stabilization than C_{se} in terms of the N_T^π index, while the reverse prediction is arrived at in terms of the $N^\pi(CH_3-CH_3)$ index. Similarly, σ aromaticity as demonstrated by the in plane $H(1s)-H(1s)$ overlap population is at a maximum in the C_{ss} conformation. Finally, the nuclear-nuclear repulsion which constitutes an index of "steric effects" varies as follows (calculated at the 4-31G level):

	$E_N(\text{rel}), \text{kcal/mol}$
C_{ee}	0.000
C_{se}	166.770
C_{ss}	441.390

Table VI

Conformation	C_{ss}	T_{ss}	C_{se}	T_{se}	C_{ee}	T_{ee}
$E_{rel}, \text{kcal/mol}$	(4-31G)	2.85	3.71	2.31	1.81	1.86
N_T^π	(4-31G)	0.9835	0.9503	0.9604	0.9580	0.9640
$N^\pi(CH_3-CH_3)$	(4-31G)	0.0034	0.000	0.0006	0.000	0.0005
$E_{rel}, \text{kcal/mol}$	(STO-4G)	2.64	3.03	2.16	1.50	1.85
N_T^π	(STO-4G)	0.9255	0.9206	0.9283	0.9250	0.9280
$N^\pi(CH_3-CH_3)$	(STO-4G)	0.0003	0.000	0.0002	0.000	0.000

Table VII

	CE $\pi + \sigma$ aromaticity		TE $\pi + \sigma$ aromaticity		C_{ee} $\pi + \sigma$ aromaticity		T_{ee} $\pi + \sigma$ aromaticity	
Rel energy, ²² kcal/mol	0.0	1.50	Rel energy, kcal/mol		1.860	0.000		(4-31G)
$N^\pi(\text{CH}-\text{F})^{23}$	0.00003	0.00007	$N^\pi(\text{CH}_3-\text{CH}_3)$		0.0005	0.000		(4-31G)
$N^\sigma(\text{H}-\text{F})^{23}$	0.00088	0.00003	$N^\sigma(\text{H}-\text{H})$		0.00093	0.00000		(4-31G)
E_N^{22} au	115.7611	113.2491	E_N au		117.86824	115.56831		(4-31G)

Chart I

Transformation	Barrier, kcal/mol		ΔN_T^π		$\Delta N^\pi(\text{CH}_3-\text{CH}_3)$	
	(4-31G)	(STO-4G)	(4-31G)	(STO-4G)	(4-31G)	(STO-4G)
(a) $C_{ee} \rightarrow C_{se}$	0.450	0.319	<u>-0.0036</u>	<u>0.0036</u>	0.0001	0.0002
(b) $T_{ee} \rightarrow T_{se}$	1.814	1.495	<u>-0.0315</u>	<u>-0.0019</u>	0.0000	0.0000

We can say, therefore, that the C_{ee} conformation is more stable than the C_{ss} and C_{se} conformation due to the stabilizing effect of σ aromaticity, which is largest in the C_{ee} conformation, as well as smaller nuclear-nuclear repulsion.

The power of the orbital symmetry analysis presented in the first section becomes readily apparent in the comparison between *cis*- and *trans*-2-butenes existing in the same conformation. The calculated orders of stability of these conformational pairs are $C_{ss} > T_{ss}$, $T_{se} > C_{se}$, and $T_{ee} > C_{ee}$. In the first case, steric effects clearly favor the T_{ss} conformation but they are dominated by the π aromatic character of the C_{ss} conformation. That is, nonbonded attraction is the key electronic factor which favors the "more crowded" conformation, C_{ss} , over the "less crowded" T_{ss} conformation. Here, both N_T^π and $N^\pi(\text{CH}_3-\text{CH}_3)$ indices with respect to both basis sets attest to the veracity of this statement. Also, it can be seen that the consequences of charge transfer in the relative π bonding of the C_{ss} and T_{ss} conformations as predicted by the orbital symmetry approach are confirmed by the ab initio calculations (Table II). Specifically, it can be seen that the percentage of correct predictions is 60% in the case of the STO-4G basis set and 60% in the case of the 4-31G basis set. This is a very good track record given the neglect of overlap in the formulation of the predictions. Furthermore, the only prediction in significant disagreement with the ab initio result concerns the relative π bonding of the C_3-C_4 atom pair in the C_{ss} and T_{ss} conformations. The reasons for this disagreement are easy to understand. Thus, while the predictions are based upon a rigid rotor model, the ab initio results refer to geometry optimized structures. The smaller C_3-C_4 bond length in the C_{ss} conformation relative to that in the T_{ss} conformation enforces a greater C_3-C_4 π overlap which gives rise to the disagreement noted. In this connection, it is interesting to note that the shrinking of both the C_2-C_3 and C_3-C_4 bond lengths in the C_{ss} relative to the T_{ss} conformation constitutes relaxation mechanisms consistent with the idea that the C_{ss} conformation is a Hückel π aromatic structure. Obviously, an argument based on "steric effects" would have led one to expect larger C_2-C_3 and C_3-C_4 bond lengths in C_{ss} rather than T_{ss} . On the other hand, steric effects seem to dominate σ aromaticity in the case of the C_{ee} vs. T_{ee} conformations. These results suggest that in the case of 2-butene, π aromaticity is more important than σ aromaticity. Obviously, the relative energy of the C_{se} and T_{se} conformations is dominated by steric effects since no appreciable π or σ aromaticity is present in the C_{se} form. The analysis pre-

sented above clearly demonstrates that similar electronic factors obtain in the case of geometric isomerism in 2-butenes and 1-fluoropropene, a typical 1-substituted propene.⁷ In the latter case, nonbonded attractive effects dominate steric effects while the reverse situation obtains in the former case. The electronic similarities of the 2-butene and 1-fluoropropene systems are best illustrated by examination of the data shown in Table VII. Of course, the data for the 1-fluoropropenes are extracted from SCF-MO-INDO calculations, while those for the 2-butenes are from ab initio calculations. Furthermore, the $N^\pi(\text{CH}_3-\text{CH}_3)$ and N_T^π indices do not parallel each other with the 4-31G basis set. Despite these imperfections, one can confidently say that the combination of σ and π effects results in a bias for a preferred *cis* geometry in both systems.

The barrier to methyl rotation in *cis*-2-butene is the energy difference between the C_{ee} and C_{se} conformations with the C_{ee} conformation being an energy minimum and the C_{se} conformation an energy maximum. Similarly, the methyl rotational barriers in *trans*-2-butene is the energy difference between the T_{ee} and T_{se} conformations with the T_{ee} conformation being the energy minimum and T_{se} the energy maximum. The rotational barriers of *cis*- and *trans*-2-butene as well as the change in the total π overlap population, ΔN_T^π , and the change in the $(\text{CH}_3-\text{CH}_3)$ π overlap population, $\Delta N^\pi(\text{CH}_3-\text{CH}_3)$, are shown in Chart I.

The relative magnitude of the barriers in (a) and (b) can be understood by reference to either ΔN_T^π or $\Delta N^\pi(\text{CH}_3-\text{CH}_3)$ indices. With the exception of the anomalous entry shown underlined, one can summarize the conclusions based on these data by saying that transformation (a) enjoys an enhancement of π nonbonded attraction while transformation (b) undergoes a decrease of π nonbonded attraction. Furthermore, in all cases $\Delta N(\text{cis}) - \Delta N(\text{trans})$ is a positive quantity; i.e., the anomalous entry, which has been encountered before, has no effect on the final conclusions. On the other hand, there is a decrease in σ nonbonded attraction in transformation (a), while such an effect is absent in transformation (b). However, as we have seen, the change in π aromaticity is expected to dominate the change in σ aromaticity, leading to a smaller barrier for the *cis* isomer.

Once more, it is interesting to compare the relative magnitude of the methyl rotational barriers in the *cis* and *trans* isomers of the two systems 2-butene and 1-fluoropropene. In one of our previous works we suggested that the greater stability of *cis*-1-fluoropropene and related molecules rela-

tive to their trans isomers as well as the lower methyl rotation barrier in the cis as compared to the trans isomer were both consequences of π attractive nonbonded interactions which obtain in the cis form.⁷ In the case of the cis isomer, the barrier to methyl rotation is the energy difference between the eclipsed conformation CE and the staggered conformation CS with the CE conformation being the energy minimum and the CS conformation being an energy maximum. Similarly, in the trans isomer the methyl rotational barrier is the energy difference between the TE conformation and the TS conformation with the TE conformation being an energy maximum.

The rotational barriers of *cis*- and *trans*-1-fluoropropene as well as the change in the total π overlap population, $\Delta N_{T\pi}(\text{CH}_3\text{-F})$, as calculated by the SCF-MO-INDO method, are shown in Chart II. Specifi-

Chart II

Transformation	Barrier, kcal/mol	$\Delta N_{T\pi}$	$\Delta N_{\pi}(\text{CH}_3\text{-F})$
(a) CE \rightarrow CS	1.569	0.00099	0.00029
(b) TE \rightarrow TS	1.996	0.00038	0.00001

cally, one finds that in comparing rotational barriers in the cis and trans isomers, the quantities $\Delta N_{T\pi}(\text{cis}) - \Delta N_{T\pi}(\text{trans})$ or $\Delta N_{\pi}(\text{X-Y})(\text{cis}) - \Delta N_{\pi}(\text{X-Y})(\text{trans})$ are both positive for either 2-butene or 1-fluoropropene. Hence, transformation (a) is more favorable than transformation (b) because of an increase in π nonbonded attraction present in the former case and absent in the latter case. That is, transformation (a) involves a 0.00099 change in the total π overlap population and a 0.00029 change in the $(\text{CH}_3\text{-F})$ π overlap population while transformation (b) involves a 0.00038 change in the total π overlap population and a 0.00001 change in the $(\text{CH}_3\text{-F})$ π overlap population. On the other hand, transformation (a) is less favored than transformation (b) because of a decrease in σ nonbonded attraction in the former case while such an effect is absent in the latter case. However, the change in π aromaticity is expected to dominate the change in σ aromaticity. The comparison of rotational isomerism in *cis*-2-butene and 1-fluoropropene illustrates the electronic similarities which obtain in these two problems. Specifically, one finds that in comparing rotational barriers in the cis and trans isomers, the quantities $\Delta N_{T\pi}(\text{cis}) - \Delta N_{T\pi}(\text{trans})$ or $\Delta N_{\pi}(\text{X-Y})(\text{cis}) - \Delta N_{\pi}(\text{X-Y})(\text{trans})$ are both positive for either 2-butene or 1-fluoropropene. However, the key difference between these two molecules amounts to the fact that the structure of 1-fluoropropene is dominated by π nonbonded attraction while the structure of 2-butene is dominated by steric effects. This is illustrated in Figure 3 which clearly shows that the smaller rotational barrier in *cis*- compared to *trans*-fluoropropene is due to a stabilization of the maximum relative to the minimum by π nonbonded attraction while, in contrast, the smaller barrier in *cis*- compared to *trans*-2-butene is due to a destabilization of the minimum relative to the maximum due to steric effects. This study reveals that similar trends, e.g., the difference in the methyl rotational barrier, can be due to similar electronic effects but an opposite balance of one-electron and steric effects. To put it crudely, attractive nonbonded effects may elude the novice theoretician because they may be masked by steric effects. However, a careful inspection of molecular wave functions is always sufficient to reveal their presence. Indeed, one may say that nonbonded attraction is visible in 1-substituted propenes and other mono and disubstituted olefins but invisible in 2-butenes and other 1,2-dialkylethylenes. This "invisible" nonbonded attraction can manifest itself into experimentally detectable molecular properties

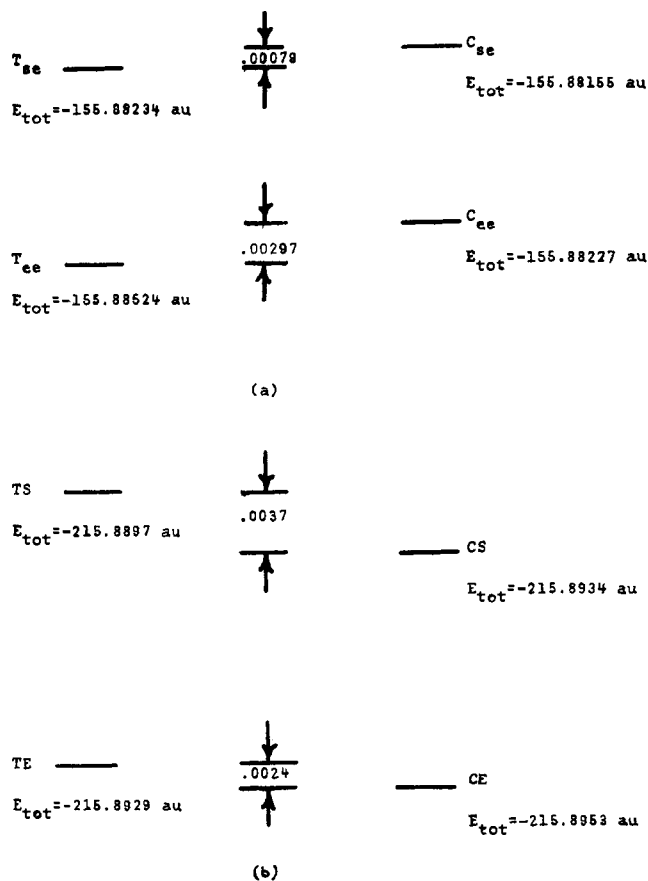
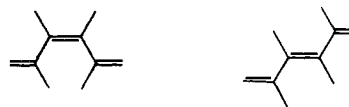

Figure 3. Energies of maxima and minima in the methyl rotational curves of (a) *cis*- and *trans*-2-butene (this work) and (b) *cis*- and *trans*-1-fluoropropene (ref 22).

and this topic will be the subject of a forthcoming publication.

Finally, we would like to comment on possible extensions of the conclusions reached in this work to other systems. For example, 2-butene is a system which is π isoconjugate to a 1,3,5-triene system. Accordingly, one can predict, by analogy, that the most stable conformation of *cis*- and *trans*-1,3,5-hexatrienes will be the ones shown below with the trans isomer being expected to be more stable than the cis. Indeed, it turns out that the energy difference between



the cis and trans isomers of 1,3,5-hexatriene is 1.1 kcal/mol in favor of the trans isomer,²⁴ e.g., nearly identical with the energy difference between the cis and trans isomers of 2-butene. We suggest that the conformational preferences of alkenes and their corresponding π isoconjugate structures are directly linked to the extent that the balance of steric and nonbonded attractive effects is similar in these two types of molecules.

Acknowledgment. We thank the donors of the Petroleum Research Fund, administered by the American Chemical Society, and the Research Corporation for partial support of this work. We also wish to thank Professors J. A. Pople and W. J. Hehre for a preprint describing their independent work on related topics. Furthermore, a NATO Research Grant to N.D.E. and F.B. is gratefully acknowledged.

References and Notes

- (1) (a) University of Washington; (b) Università di Bologna.
- (2) (a) R. T. Morrison and R. N. Boyd, "Organic Chemistry", 3rd ed, Allyn and Bacon, Boston, Mass., 1973, p 185; (b) G. B. Kistiakowsky, J. R. Ruhoff, H. A. Smith, and W. E. Vaughan, *J. Am. Chem. Soc.*, **58**, 137 (1936).
- (3) For typical examples, see E. J. Prosen, F. W. Maron, and F. D. Rossini, *J. Res. Natl. Bur. Stand.*, **46**, 106 (1951); R. B. Turner, D. E. Neltleton, and M. Perelman, *J. Am. Chem. Soc.*, **80**, 1430 (1958); K. Yates and R. S. McDonald, *ibid.*, **93**, 6297 (1971); K. Yates and R. S. McDonald, *J. Org. Chem.*, **38**, 2465 (1973).
- (4) W. A. Sheppard and C. M. Sharts, "Organic Fluorine Chemistry", W. A. Benjamin, New York, N.Y., 1969, Chapter 3.
- (5) N. D. Epiotis, *J. Am. Chem. Soc.*, **95**, 3087 (1973).
- (6) N. D. Epiotis and W. Cherry, *J. Chem. Soc., Chem. Commun.*, 278 (1973).
- (7) N. D. Epiotis, D. Bjorkquist, L. Bjorkquist, and S. Sarkanen, *J. Am. Chem. Soc.*, **95**, 7558 (1973).
- (8) N. D. Epiotis, S. Sarkanen, D. Bjorkquist, L. Bjorkquist, and R. Yates, *J. Am. Chem. Soc.*, **96**, 4075 (1974).
- (9) For data on 1,2-dialkylethylenes see ref 2b and 3. For the preferred conformation of *n*-butane, a typical 1,2-dialkylethane, see E. L. Eliel, "Stereochemistry of Carbon Compounds", McGraw-Hill, New York, N.Y., 1962, Chapter 6.
- (10) The foremost example of the success of one-electron MO theory in dealing with chemical problems of "real" interest is the Woodward-Hoffmann analysis of the stereochemistry of pericyclic reactions: R. B. Woodward and R. Hoffmann, "The Conservation of Orbital Symmetry", Academic Press, New York, N.Y., 1970.
- (11) For a discussion of this and other approximations of the interaction matrix element, see S. P. McGlynn, L. G. Vanquickenborne, M. Kinoshita, and D. G. Carroll, "Introduction to Applied Quantum Chemistry", Holt, Rinehart and Winston, New York, N.Y., 1972.
- (12) The dependence of the four-electron overlap repulsion upon the mean of the energy of the interacting levels has been discussed previously in the literature: N. C. Baird and R. M. West, *J. Am. Chem. Soc.*, **93**, 4427 (1971); K. Müller, *Helv. Chim. Acta*, **53**, 1112 (1970).
- (13) This pattern is familiar to the theoretical organic chemist since it reflects nothing more than the fact that the B fragment of the C_{8s} conformation resembles an antiaromatic structure while the B fragment of the T_{8s} conformation resembles a nonaromatic structure. The changes in the energies of the π MO's of the B fragment which accompany the $T_{8s} \rightarrow C_{8s}$ transformation are characteristic of the changes in the energies of the π MO's accompanying any nonaromatic \rightarrow antiaromatic transformation.
- (14) N. D. Epiotis, and R. L. Yates, *J. Am. Chem. Soc.*, in press.
- (15) L. Radom and J. A. Pople, *J. Am. Chem. Soc.*, **92**, 4786 (1970).
- (16) W. J. Hehre, R. F. Stewart, and J. A. Pople, *J. Chem. Phys.*, **51**, 2657 (1969).
- (17) J. A. Pople and M. S. Gordon, *J. Am. Chem. Soc.*, **89**, 4253 (1967).
- (18) W. J. Hehre, W. A. Lathan, R. Ditchfield, M. D. Newton, and J. A. Pople, "Quantum Chemistry Program Exchange", Indiana University, Bloomington, Ind.
- (19) (a) A. Almennigen, I. M. Anfinsen, and A. Haaland, *Acta Chim. Scand.*, **24**, 43 (1970); (b) T. N. Sarachman, *J. Chem. Phys.*, **49**, 3146 (1963).
- (20) R. Ditchfield, W. J. Hehre, and J. A. Pople, *J. Chem. Phys.*, **54**, 724 (1971).
- (21) J. P. Lowe, *J. Am. Chem. Soc.*, **92**, 3799 (1970); W. J. Hehre and L. Salem, *J. Chem. Soc., Chem. Commun.*, 754 (1973).
- (22) Energy data taken from the *ab initio* calculations of A. D. English and W. E. Palke, *J. Am. Chem. Soc.*, **95**, 8536 (1973).
- (23) The (CH_3-F) π and $(H-F)$ σ overlap populations were calculated for the CE and TE conformations of 1-fluoropropene by the SCF-MO-INDO method. For a discussion of this semiempirical method see: J. A. Pople and D. L. Beveridge, "Approximate Molecular Orbital Theory", McGraw-Hill, New York, N.Y., 1970. The labels CE and TE refer to the cis and trans isomers, respectively, in which the in plane hydrogen of the methyl group is eclipsed by the double bond.
- (24) R. B. Turner, B. J. Mallon, M. Tichy, W. E. Doering, W. R. Roth, and G. Schroder, *J. Am. Chem. Soc.*, **95**, 8605 (1973).

Can a Square or Effectively Square Singlet Be the Ground State of Cyclobutadiene?

Weston Thatcher Borden

Contribution from the Department of Chemistry, University of Washington, Seattle, Washington 98195. Received January 17, 1975

Abstract: The question posed in the title can be answered in the affirmative when the important effects of electron repulsion in open-shell systems are considered. Repulsion between the two electrons in the nonbonding MO's of cyclobutadiene is minimized in a square geometry, resulting in a flat curve for rectangular distortion in the lowest singlet state. A flat curve for distortion in this state implies that its stabilization by a pseudo-Jahn-Teller effect is not responsible for dropping its energy below that of the triplet state. It is shown, however, that the singlet can profit by CI from a reduction, unavailable to the triplet, in the repulsion between the nonbonding electrons and those in ψ_1 and that it is this effect that makes the singlet the ground state of cyclobutadiene.

The available experimental evidence strongly indicates that cyclobutadiene has a singlet ground state.¹ It has long been supposed that a singlet ground state for cyclobutadiene is the result of a distortion to a rectangular geometry that drops the energy of this state below that of the triplet, which is expected to have its energy minimum at a square geometry.² However, recent ir studies of matrix isolated cyclobutadiene have shown that the geometry of the state observed must be square³ or effectively square.⁴ In this paper MO theory is used to investigate whether, when cognizance is taken of the importance of the effects of electron repulsion in open-shell systems,⁷ a square or effectively square singlet can, in fact, be the ground state of cyclobutadiene.

In order that cyclobutadiene have a square (or effectively square) singlet as its ground state, two conditions must be fulfilled: (a) the lowest singlet must have its energy minimum at a square geometry (or the barrier to conversion of

one distorted geometry to another must be very small) and (b) the lowest singlet must lie below the triplet. With regard to the first condition, it should be noted that the lowest singlet state of square cyclobutadiene ($^1B_{1g}$) is nondegenerate^{2,7a,d} and so is not subject to the consequences of the Jahn-Teller theorem.⁸ Although there is a low-lying singlet ($^1A_{1g}$) that can be mixed with $^1B_{1g}$ by a vibration that converts square to rectangular cyclobutadiene,² there is no guarantee that this pseudo-Jahn-Teller effect⁹ will, in fact, produce any appreciable energy lowering. The reason is that although the distortion does lead to an increase in bonding, it is also accompanied by an increase in electron repulsion. Only in the square geometry of cyclobutadiene (and, more generally, in the most symmetrical geometry of other $[4n]$ annulenes)^{7a} are the two electrons in the nonbonding MO's confined to different sets of atoms, so that the wave function for these electrons contains no ionic